

auto electrical parts

Technical Information Sheet

Part No. 0-420-40

Rectangular work lamp with black plastic body and glass lens. Supplied without H3 bulb. Single bolt fixing.
l 139 x w 95 x h 139mm.

Additional information

Connection by 2 x 6.3mm lucar blade terminals. Bracket allows for tilt through ~140°.



Technical Drawing (not to scale)

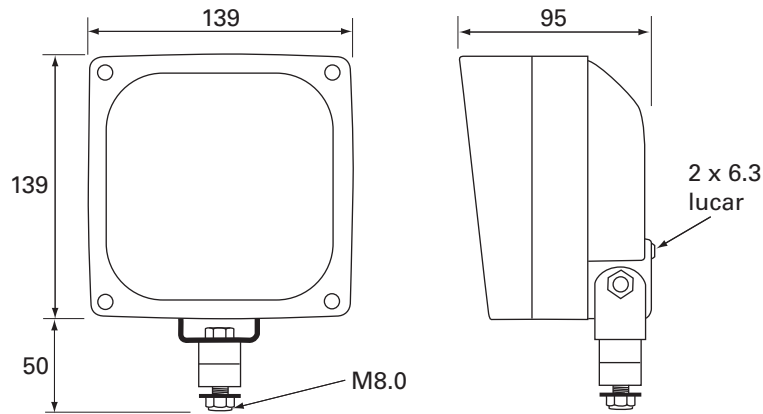

Specification

Type	Work lamp
Bulb	H3
Lens	Glass
Reflector	Metal
Housing	Plastic
Weight	620g
Dimensions	l 139 x w 95 x h 189mm (including bracket)

The information contained in this document is correct to the best of our knowledge at the time of printing. However, specifications may change at any time without notice.